

NEWPORT BRASS

Flawless Beauty. From Faucet to Finish.

INSTALLATION INSTRUCTIONS INSTRUCCIONES DE INSTALACIÓN

VALVE
VÁLVULA

IN-WALL ROUGH
MONTAJE EN CUBIERTA

IN-LINE OUTLET
SALIDA EN LÍNEA

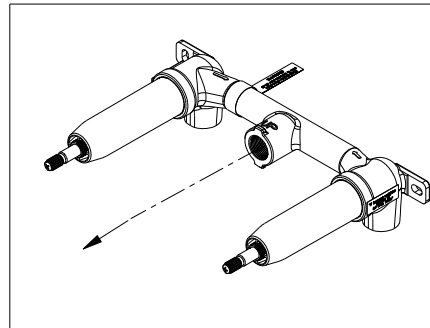

OR

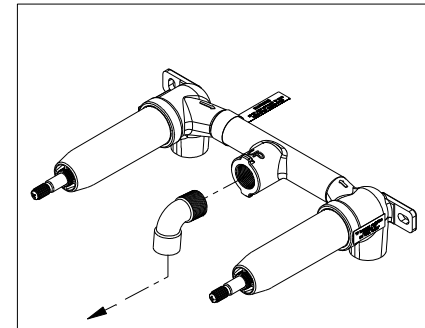

REPRESENTATIVE IMAGE SHOWN IDENTIFY YOUR PRODUCT
IMAGEN REPRESENTATIVA MOSTRADA IDENTIFIQUE SU PRODUCTO

RECOMMEND INSTALLATION BY A PROFESSIONAL PLUMBING CONTRACTOR
RECOMIENDE LA INSTALACIÓN A UN CONTRATISTA DE PLOMERÍA PROFESIONAL

NOTE: THE USE OF PETROLEUM BASE PLUMBERS PUTTY ON OUR PRODUCTS WILL NULLIFY THE WARRANTY.
WE RECOMMEND THE USE OF CLEAR SILICONE SEALING MATERIALS.
NOTA: EL USO DE MASILLA DE PLOMERÍA A BASE DE PETRÓLEO EN NUESTROS PRODUCTOS ANULARÁ LA GARANTÍA.
RECOMENDAMOS EL USO DE MATERIALES DE SELLADO DE SILICONA TRANSPARENTE.

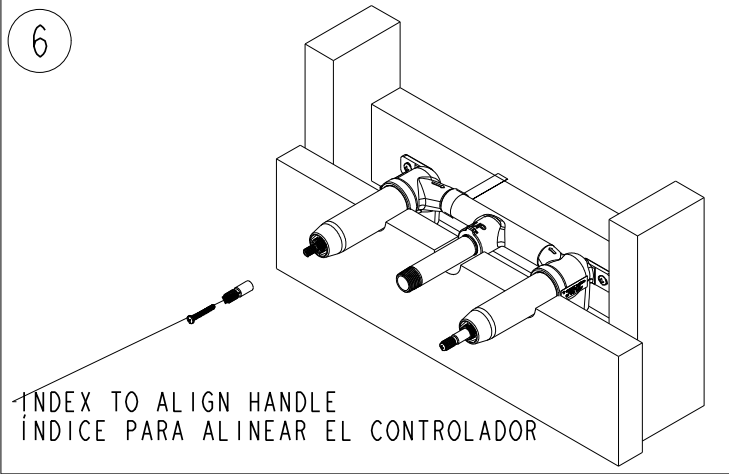
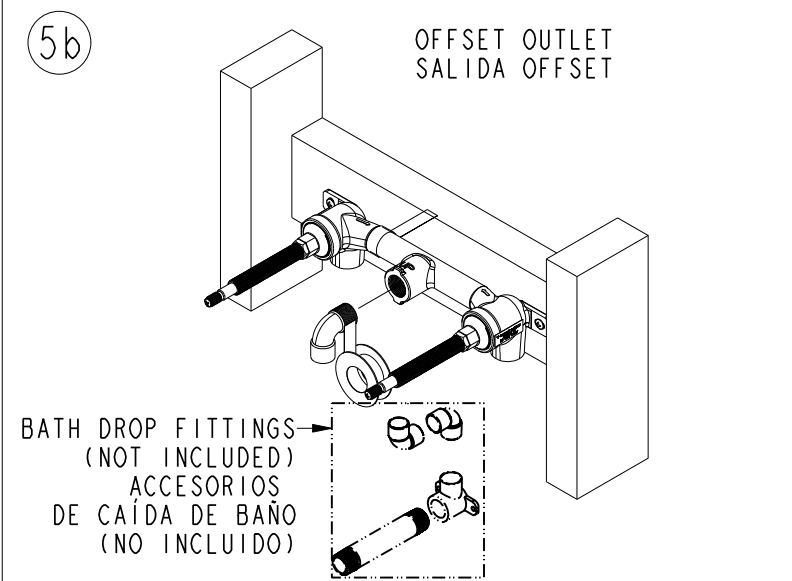
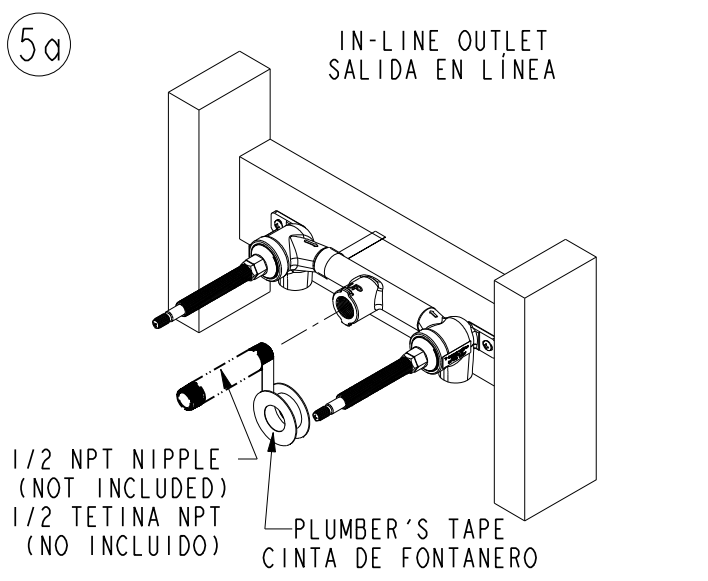
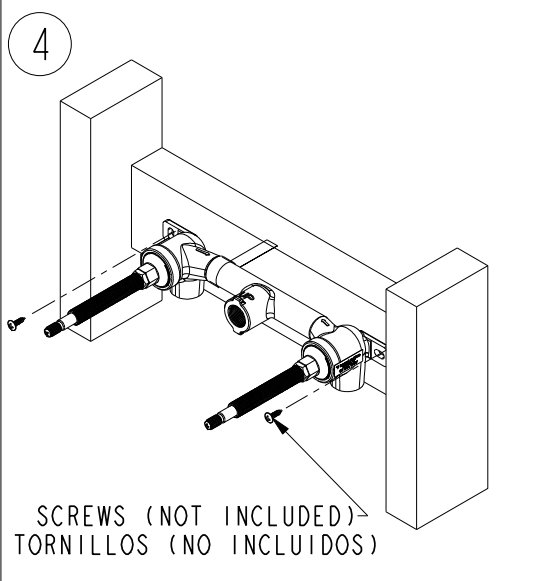
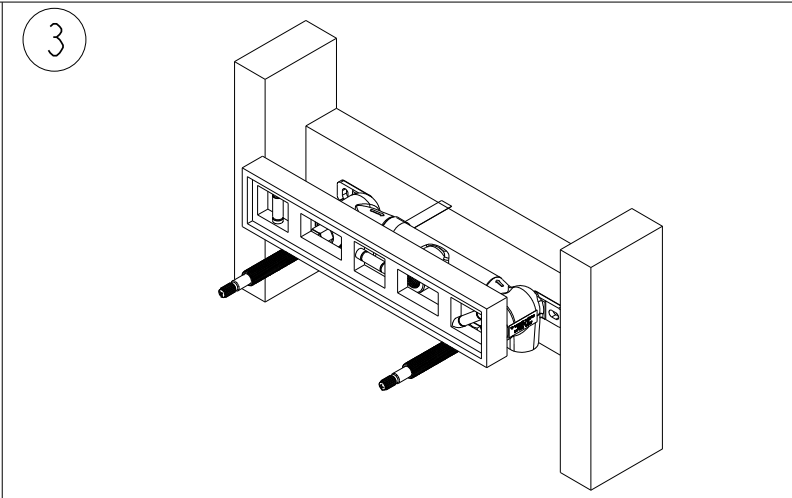
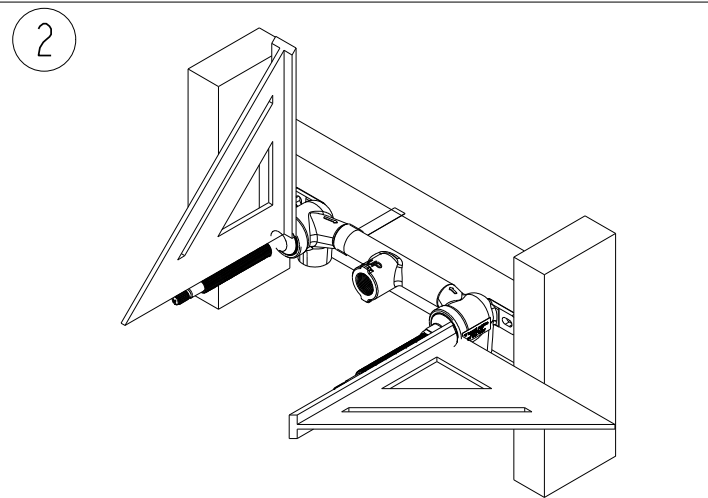
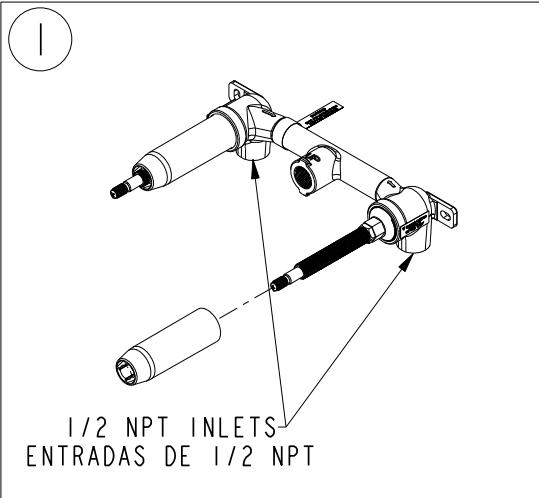

⚠ To prevent severe damage to the valve, any solder/braze process must be performed at a minimum of 4" [101.6] mm from ports. Otherwise the cartridges must be removed from the valve body and reinstalled to torqued valves.
Para evitar daños graves a la válvula, cualquier proceso de soldadura/soldadura fuerte debe realizarse a un mínimo de 4" [101,6] mm de los puertos. De lo contrario, los cartuchos deben retirarse del cuerpo de la válvula y volver a instalarse a los valores de par.

TORQUE TO 9-11 FT-LBS.
APRIETE A 9-11 FT-LBS.

3-1/4" [83]mm MIN
4-1/2" [114]mm MAX

TORQUE TO 9-11 FT-LBS.
APRIETE A 9-11 FT-LBS.

Ø 1-3/8" [35]mm